



CITY OF GLENDALE
 DEVELOPMENT SERVICES DEPARTMENT
 5754 W. GLENN DR.
 GLENDALE, AZ 85301
 623.930.2800
 www.GlendaleAZ.com

PERMIT/PLAN REVIEW APPLICATION

SINGLE FAMILY RESIDENTIAL

| | | | |
|---|---------------------------|--|------------------|
| PROJECT NAME: | | PROJECT ADDRESS (STREET, CITY, STATE, ZIP CODE): | |
| | | PARCEL NUMBER: | ZONING DISTRICT: |
| PROJECT DESCRIPTION/SCOPE OF WORK: | | | |
| CONSTRUCTION VALUATION*: | CONSTRUCTION TYPE: | OCCUPANCY TYPE: | |
| SUBDIVISION: | | | |
| UTILITY COMPANY: <input type="checkbox"/> APS <input type="checkbox"/> SRP <input type="checkbox"/> SWG | CONSTRUCTION AREA (SF)**: | | |

| | |
|--|----------------|
| APPLICANT NAME/COMPANY NAME/LEGAL AGENT (If Applicable): | |
| MAILING ADDRESS (STREET, CITY, STATE, ZIP CODE): | |
| PHONE NUMBER: | EMAIL ADDRESS: |

| | |
|--|----------------|
| PROPERTY OWNER NAME: | |
| MAILING ADDRESS (STREET, CITY, STATE, ZIP CODE): | |
| PHONE NUMBER: | EMAIL ADDRESS: |

| | | |
|---|-------------------------|----------------------------|
| GENERAL CONTRACTOR: | | |
| MAILING ADDRESS (STREET, SUITE, CITY, STATE, ZIP CODE): | | |
| PHONE NUMBER: | EMAIL ADDRESS: | |
| AZ ROC NUMBER: | LICENSE CLASSIFICATION: | COG SALES TAX LICENSE No.: |

| | | |
|---|-------|------|
| I (the undersigned) understand and agree that the issuance of the permit for which I am applying does not relieve me of the responsibility that this work will be done in conformity with the laws of the City of Glendale, Maricopa County and the State of Arizona. I further agree that the City of Glendale Development Services Department has the authority to enforce adopted building and fire codes and regulations not indicated on the construction documents. | | |
| SIGNATURE***: | DATE: | FEE: |

- NOTES:
- * Construction Valuation shall include cost of material and labor for proposed work that is included in this application.
 - ** Provide area included for construction that is proposed in this application.
 - *** All applications will require a signature from the applicant prior to submittal acceptance (Digital Signature is acceptable)

| | |
|-----------------------|--------------------|
| STAFF USE ONLY | |
| COG PROJECT NUMBER: | COG PERMIT NUMBER: |
| PLAN REVIEW FEES: | PERMIT FEES: |

GAS LINE DIAGRAM - SITE PLAN

* PROJECT NAME: _____
 * APPLICANT NAME: _____
 * PHONE NUMBER: _____
 * PROPERTY ADDRESS: _____

* NEW PIPE LINE INFORMATION:
 ABOVE GROUND
 BELOW GROUND
 PIPE BURIED DEPTH = _____
 TRACER WIRE GAUGE = _____
 TOTAL PIPE LENGTH = _____

GENERAL NOTE:
 SEE EQUIPMENT DATA PLATE
 FOR BTU/CFH INFORMATION.

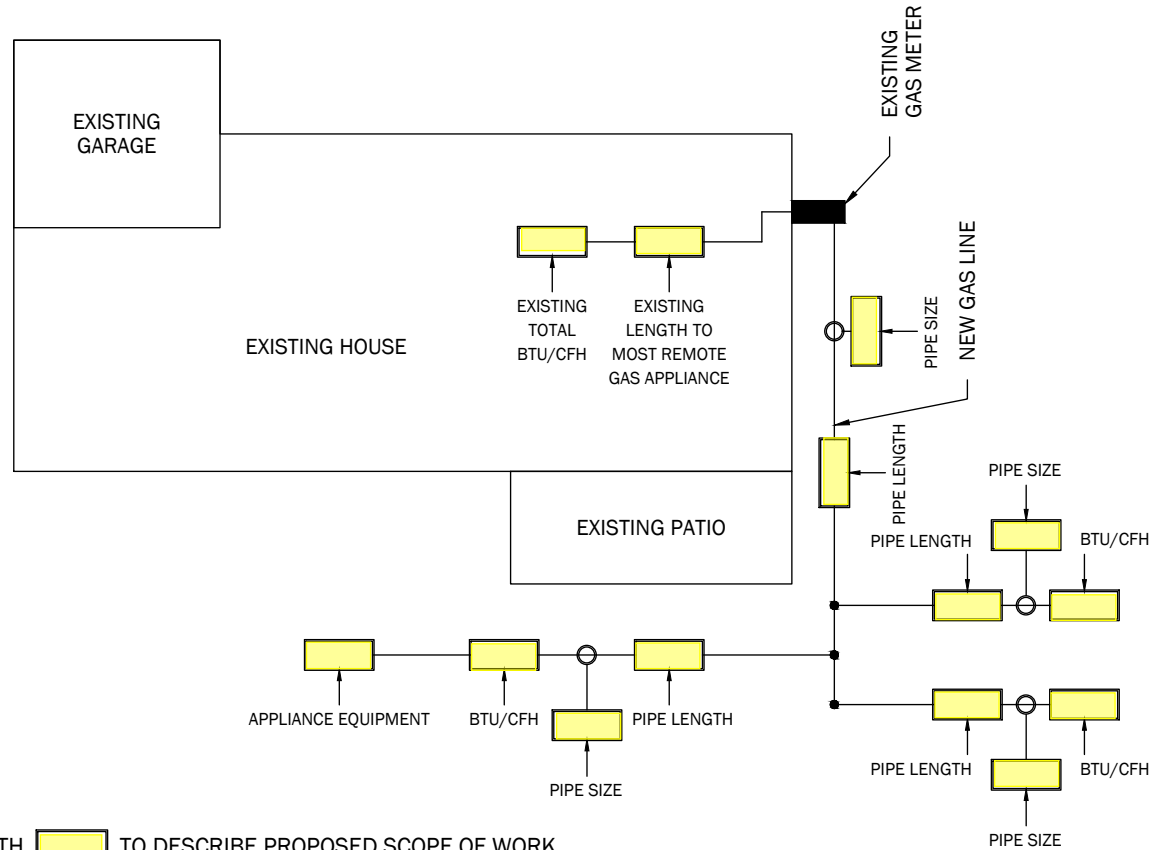

NOTES:

1. PLEASE FILL ALL SPACES DESIGNATED WITH TO DESCRIBE PROPOSED SCOPE OF WORK.
2. POLYETHYLENE (PE): OUTDOORS, UNDERGROUND ONLY. REQUIRES A YELLOW INSULATED COPPER TRACER WIRE NOT LESS THAN 18 AWG AND THE INSULATION SHALL BE SUITABLE FOR DIRECT BURIAL. THE TRACER WIRE SHALL TERMINATE ABOVE GROUND AT EACH END OF THE NON-METALLIC PIPING.
 CONNECTIONS SHALL BE MADE OUTDOORS AND UNDERGROUND BETWEEN METALLIC AND PLASTIC PIPING AND SHALL BE MADE ONLY WITH TRANSITION FITTINGS CONFORMING WITH ASTM D2513 (CATEGORY I) OR ASTM F1973.
3. METALLIC SCHEDULE 40 PIPE: SHALL BE INSTALLED A MINIMUM 3.5" ABOVE GROUND AND ROOFS. IF INSTALLED BELOW GROUND SHALL BE PROTECTIVELY COATED BY A LISTED COATING APPLICATOR (GALVANIZED PIPE IS NOT AN ACCEPTABLE COATING FOR BELOW GROUND).
 JOINTS IN PROTECTIVELY COATED PIPE SHALL BE TAPED AND PRIMER SHALL BE APPLIED PER THE TAPE MANUFACTURER'S INSTALLATION INSTRUCTIONS AND AS PROVIDED IN INSTALLATION STANDARD IAMPO IS 13-2006.
4. ALL PIPING SHALL BE BURIED A MINIMUM OF 12" BELOW GRADE EXCEPT INDIVIDUAL LINES TO OUTSIDE LIGHTS, GRILLS, OR OTHER APPLIANCES SHALL BE 8" MINIMUM BELOW GRADE, PROVIDED INSTALLATION IS APPROVED AND IS INSTALLED IN LOCATIONS NOT SUSCEPTIBLE TO PHYSICAL DAMAGE.
5. IF THE GAS PIPING IS TO BE INSTALLED BELOW A BUILDING, AN APPROVED SLEEVE WILL BE REQUIRED - PLEASE ASK FOR CITY OF GLENDALE DETAIL.



SHEET:

MP1



CITY OF GLENDALE
 DEVELOPMENT SERVICES DEPARTMENT
 5754 W. GLENN DR.
 GLENDALE, AZ 85301
 623.930.2800
 www.GlendaleAZ.com

OWNER/BUILDER ADDENDUM FORM
 RESIDENTIAL PROJECTS ONLY

| | |
|---------------|--|
| DATE: | COG PERMIT NUMBER: |
| PROJECT NAME: | PROJECT ADDRESS (STREET, CITY, STATE, ZIP CODE): |

The undersigned applicant asserts that she or he is exempt from the original contractor licensing requirement of Arizona Revised Statutes Titel 32, Chapter 10, on the basis of:

- ARS 32-1121.A.5 The applicant owns the property and shall occupy the property, and does not intend the property to be for sale or rent, and shall have the work performed by the applicant alone, or by the applicant with employees of the applicant, and/or performed by duly licensed contractor(s) all of whom are identified below or on the attached.
- ARS 32-1121.A.6 The applicant owns the property and shall have the work performed only by duly licensed contractor(s) all of whom are identified below or on the attached.

| CONTRACTOR/COMPANY NAME: | AZ ROC NUMBER: | LICENSE CLASSIFICATION: |
|--------------------------|----------------|-------------------------|
| | | |
| | | |
| | | |
| | | |
| | | |
| | | |
| | | |
| | | |
| | | |
| | | |

- ARS 32-1121.A.7 The applicant is registered architect or engineer, or employee of registered architect or engineer engaged in professional practice, not as a contractor.

The undersigned swears and affirms that the information herein is true and accurate, and acknowledges that the filing of an application containing false or incorrect information with the intent to avoid licensing or tax requirements of the State of Arizona is "unsworn falsification", a criminal misdemeanor.

| | | |
|----------------------------|-------------------------|-------|
| PRINTED NAME OF THE OWNER: | SIGNATURE OF THE OWNER: | DATE: |
|----------------------------|-------------------------|-------|